

# ALPHA900P PVD COATING SYSTEM

The large, versatile duplex coating machine



# ALPHA900P PVD COATING SYSTEM

## THE LARGE, VERSATILE COATER

The alpha900P is the efficient coating system with high throughput. You can use it to extend a demanding coating centre or to integrate it in the production of cutting tools (hobs, shaper cutters, shank tools) at an original part manufacturer (OEM).

Due to its large chamber, you can even use it as a coating system for large and heavy stamping, forming or die casting tools in corresponding operations.

### MAIN COATINGS

ARC coatings like:

- » TiN
- » CrCN
- » EXXTRAL®-plus
- » SISTRAL®
- » VARIANTIC®

### OPTIONAL COATINGS

ARC coatings like:

- » Duplex coatings
- » TiN-ultrafine
- » TiCN-ultrafine
- » EXXTRAL®-ultrafine
- » SISTRAL®-ultrafine
- » CROSAL®-plus

### SMART DESIGN FOR MORE FLEXIBILITY

- » Space-saving design with separate chamber, allowing for split setup in different parts of the factory

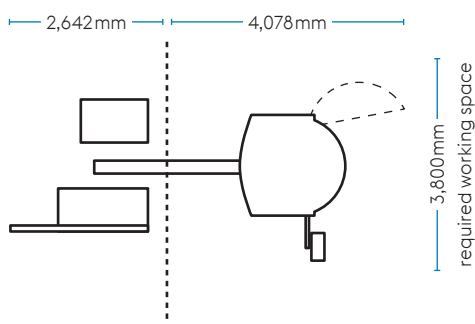

## MAIN BENEFITS

- » High plasma density
- » High flexibility, high productivity
- » Dual evaporators for high production stability and access to mixed-material coatings
- » Simple loading and intuitive operation
- » Easy to maintain
- » Low operation costs
- » Optional: SPCS equipment for access to eifeler's ultrafine coatings with extra smooth and dense surfaces
- » Optional: Duplex-PVD with additional plasma sources for in-situ plasma nitriding

## TECHNICAL DATA

Usable volume	Ø 800 mm × 880 mm
Load	max. 850 kg
Coating chamber (L × W × H)	1,100 × 1,100 × 1,355 mm
Dead weight	3,800 kg excl. batch load
Pumping station weight	250 kg
Cabinets weight	1,710 kg incl. Duplex-PVD
Distributed load	2,205 kg per sqm incl. batch load
Bias	30 kW / max. 1,000 V DC / pulsed DC
Evaporator sources	24 pcs. with each max. 125 A
Batches per day	typically 3 – 4 batches
Exemplary batch Endmills (Ø 10 × 70 mm)	1,764 pcs. per batch
Exemplary batch Hobs (Ø 100 × 150 mm)	42 pcs. per batch
Turntables	different numbers of satellites available

voestalpine eifeler Vacotec GmbH

Hansaallee 321  
40549 Düsseldorf, Germany  
T. +49 211 522-2440  
F. +49 211 522-2480  
www.eifeler.com

voestalpine

ONE STEP AHEAD.