

ALPHA400C PVD COATING SYSTEM

The door opener for tribological coatings



ALPHA400C PVD COATING SYSTEM

DOOR OPENER TO TRIBOLOGY

With the alpha400C coating system, you can produce friction-reducing coatings on reasonably sized parts, especially on carbon-base or MoS₂-base. The production of nitridic hard coatings with substrate temperatures below 250 °C / 482 °F are accessible with it as well.

The smallest magnetron sputter system in our range offers you high flexibility and short production cycles. That makes it a perfect fit for R&D divisions in production and universities.

It works great as well in production lines of original part manufacturers (OEM) – with a high throughput of similar-type parts – becoming an integral component of their production system.

MAIN COATINGS

DLC coatings like:

- » SUCASLIDE®
- » CARBON-X®

Tribological coatings like:

- » MoX2®

Optional coatings:

- » Nitridic hard coatings

COMPACT FOOTPRINT

- » Small footprint for easy integration in factory floor plan
- » Access to all sides for easy maintenance and service

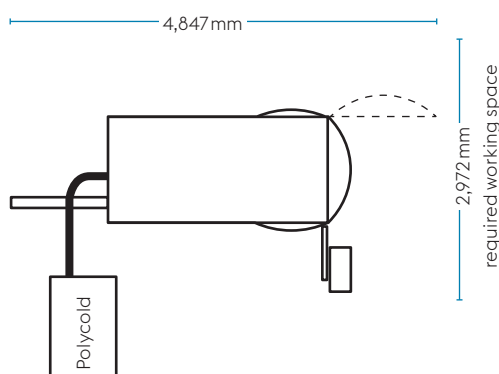

BENEFITS

- » High flexibility, high productivity
- » Cryopump for faster pumping
- » Target shutter system for high reliability
- » Access to eifeler's tribological coatings (MoX2®, DLC)
- » Simple loading and intuitive operation
- » Easy to maintain
- » Low operating costs
- » High plasma density

TECHNICAL DATA

Usable volume	Ø 450 mm × 525 mm
Load	max. 300 kg
Coating chamber (L × W × H)	775 × 630 × 750 mm
Dead weight	3,000 kg incl. separate Polycold
Distributed load	850 kg per sqm
Bias	10 kW / max. 700V DC / pulsed DC
Sputter sources	4 pcs. 643 × 145 mm, 6 kW each
Batches per day	typically 3 – 4 batches
Exemplary batch Endmills (Ø 10 × 70 mm)	432 pcs. per batch
Exemplary batch (Ø 100 × 150 mm)	24 pcs. per batch
Turntables	different numbers of satellites available

voestalpine eifeler Vacotec GmbH

Hansaallee 321

40549 Düsseldorf, Germany

T. +49 211 522-2440

F. +49 211 522-2480

www.eifeler.com

voestalpine

ONE STEP AHEAD.